

## GCD09

### Provisional Product Guide

ASME B30.5  
Imperial 85%



### Features

- 8,1 t (9 USt) capacity
- 10,12 m (33.2 ft) three-section full-power boom
- 6,4 t (7 USt) deck carrying ability
- Load sensing hydraulic proportional joystick controls
- Dual fuel and diesel engine options available
- Exclusive pivoting boom nose

# GROVE GCD09

The new GCD09 is an 8,1 t (9 USt) capacity carrydeck crane, offering a three-section 10,12 m (33.2 ft) boom, two-wheel drive / four-wheel steer capability. It also has three-position pivoting boom head for low head room clearance and out and down outriggers that can be set up in multiple configurations depending on the jobsite requirements.

## Features

### > Outriggers

The GCD09 outriggers are two-position (0% and 100%) beam/jack style with integral steel outrigger pads. Equipped with independent outrigger controls.



### > Operator cab

Simple operator cab features hydraulic joystick controls, easy-to-set up graphic RCL system, common automotive dash panel with gauges, indicator lights and rocker switches. Fully adjustable seat and tilting steering wheel are standard features. The optional enclosed cab with split door design for additional comfort.



### > Steering

The GCD09 comes standard with three steering modes: Front (two-wheel), four-wheel coordinated, and four-wheel crab steer with electronic self-alignment. Operators can choose between modes using a three-position rocker switch located on dash panel.



### > Options

- Convenience package includes pintle hitches and light grilles
- Lighting package includes amber strobe light and boom-mounted work lights
- Below-deck winch
- Air-conditioning

## GCD09 benefits

- User friendly powershift transmission. Simplifies switching between gears.
- Designed with the request for storage in mind. The hook block and downhaul weight can be stowed in the front deck storage compartment. A small compartment to the side of the machine is ideal for tie down straps.
- The compact GCD09 offers two position outriggers. This feature is ideal for those confined workspaces such as narrow aisleways.
- The dual fuel engine is ideal for indoor use and single fuel sourcing for mixed fleets of cranes and other equipment on the jobsite. Optional EPA Tier 4 Final emissions compliant without the use of a SCR or UREA injected DEF system. No Diesel Exhaust Fluid (DEF) required.



**Manitowoc Crane Care when you need it.**  
The assurance of the world's most advanced crane service and support to get you back to work fast.



**Manitowoc Finance helps you get right to work generating profits for your business.**  
Financial tools that help you capitalize on opportunity with solutions that fit your needs.

# Table of contents

Dimensions and weights .....	5
Working range .....	7
Load charts .....	8
Transportation and lifting data .....	11
Load handling .....	12
Specifications.....	13
Symbols glossary.....	15

# Dimensions and weights

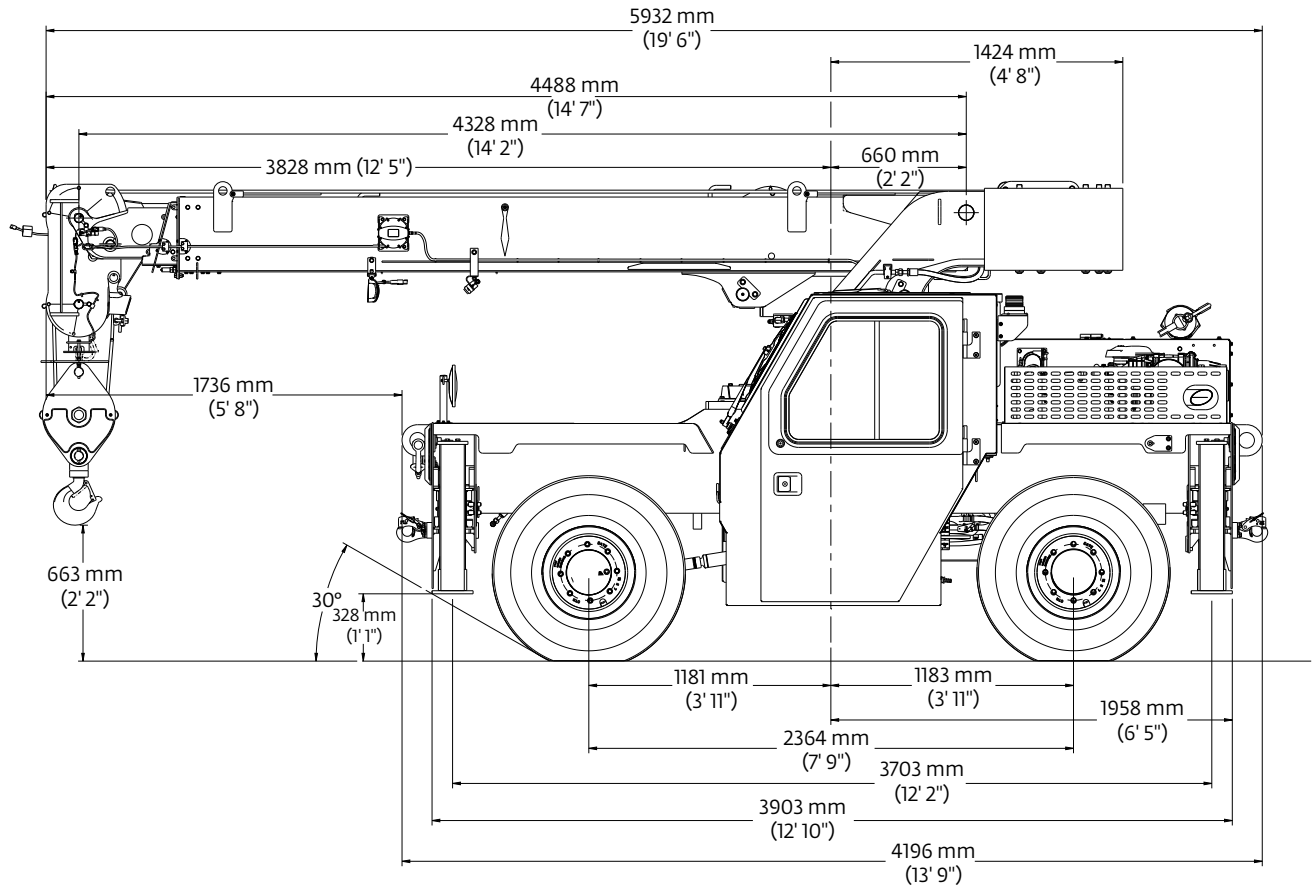

# Dimensions and weights

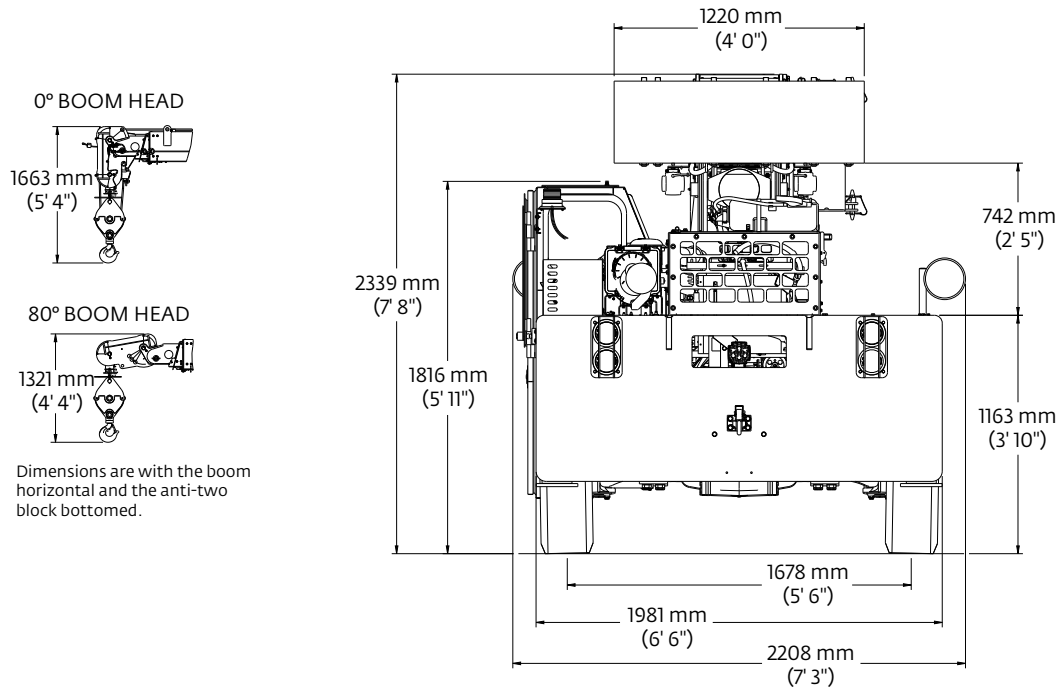

Weights						
	GVW		Front		Rear	
	kg	lb	kg	lb	kg	lb
<b>Basic machine:</b> Including 10,12 m (33.2 ft) main boom, main hoist with 36,6 m (120 ft) of wire rope, 11.3 t (12.5 USt) hook block, full counterweight, dual fuel engine and driver.	7790	17,174	3871	8534	3919	8640
<b>Add:</b> 3,66 m (12 ft) fixed swingaway extension and extension carrier brackets and downhaul weight	221	487	310	684	-89	-197
<b>Crane weight</b>	8011	17,661	4181	9218	3830	8443
<b>Basic machine:</b> Including 10,12 m (33.2 ft) main boom, main hoist with 36,6 m (120 ft) of wire rope, 11.3 t (12.5 USt) hook block, full counterweight, dual fuel engine and driver.	7790	17,174	3871	8534	3919	8640
<b>Add:</b> Enclosed cab, heater and glass	92	203	43	96	49	107
<b>Crane weight</b>	7882	17,377	3914	8630	3968	8747

# Working range

Imperial

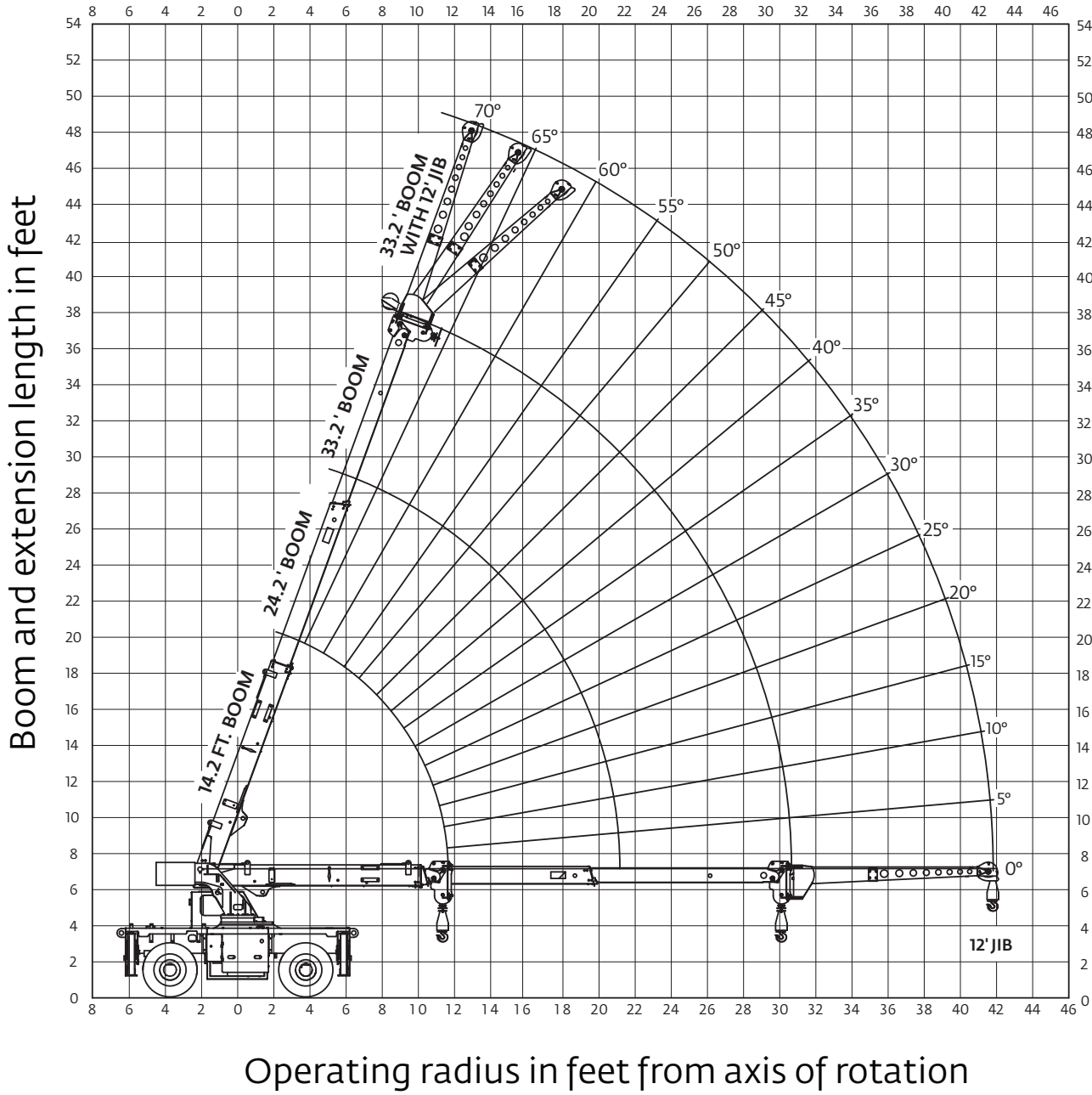

*PROVISIONAL*

*THIS CHART IS ONLY A GUIDE AND SHOULD NOT BE USED TO OPERATE THE CRANE.*

*The individual crane's load chart, operating instructions and other instructional plates must be read and understood prior to operating the crane*

# Load chart

Imperial



14.2 ft - 33.2 ft



100%



360°



Pounds



14.2 ft - 33.2 ft



100% or 0%



Defined arc  
over front



Pounds

Radius in Feet	Main Boom Length in Feet		
	14.2	24.2	33.2
5	18,000 (66)		
6	14,300 (61.5)		
8	12,000 (51)	9280 (69)	
10	10,350 (38)	9120 (63.5)	
12	7830 (0)	8040 (58)	7430 (68)
14		6820 (52)	6620 (64)
16		5470 (45.5)	5680 (60)
18		4510 (37.5)	4690 (55.5)
20		3800 (28)	3950 (51)
22		3250 (0)	3380 (46.5)
24			2920 (41)
26			2550 (35)
28			2240 (28)
30			1980 (17.5)
31			1870 (0)

NOTE: ( ) Boom angles are in degrees.

80089495

Radius in Feet	Main Boom Length in Feet		
	14.2	24.2	33.2
5	18,000 (66)		
6	14,300 (61.5)		
8	12,000 (51)	9280 (69)	
10	10,350 (38)	9120 (63.5)	
12	7830 (0)	8040 (58)	7430 (68)
14		7200 (52)	6620 (64)
16		5980 (45.5)	5990 (60)
18		4940 (37.5)	5010 (55.5)
20		4170 (28)	4230 (51)
22		3570 (0)	3640 (46.5)
24			3160 (41)
26			2790 (35)
28			2470 (28)
30			2210 (17.5)
31			2120 (0)

NOTE: ( ) Boom angles are in degrees.

80089497

**PROVISIONAL**

THIS CHART IS ONLY A GUIDE AND SHOULD NOT BE USED TO OPERATE THE CRANE.

The individual crane's load chart, operating instructions and other instructional plates must be read and understood prior to operating the crane

# Load chart

Imperial

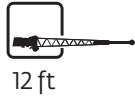

Pounds

Main Boom Angle (°)	0° OFFSET		15° OFFSET		30° OFFSET	
	Up to 24.2' boom length	Up to 33.2' boom length	Up to 24.2' boom length	Up to 33.2' boom length	Up to 24.2' boom length	Up to 33.2' boom length
70	7590	5220	5420	4280	4370	3630
65	5850	4290	4500	3590	3800	3160
60	4720	3300	3860	2880	3370	2660
55	3980	2750	3390	2460	3040	2310
50	3300	2280	2950	2090	2730	1970
45	2860	1920	2600	1800	2450	1730
40	2540	1690	2370	1600	2270	1550
35	2320	1500	2190	1460	2150	1430
30	2130	1380	2050	1360	2050	1330
25	1960	1280	1930	1260		
20	1870	1200	1870	1200		
15	1810	1130	1840	1150		
10	1770	1110				
5	1740	1080				
0	1720	1080				

80089498

NOTES:

- 12 ft boom extension may be used for single line lifting service only.
- WARNING: Operation of this machine with heavier loads than the capacities listed is strictly prohibited. Machine tipping with boom extension occurs rapidly and without advance warning.

**PROVISIONAL**

THIS CHART IS ONLY A GUIDE AND SHOULD NOT BE USED TO OPERATE THE CRANE.

The individual crane's load chart, operating instructions and other instructional plates must be read and understood prior to operating the crane

# Load chart

Imperial



Radius in Feet	Defined Arc 8° Over Front	Stationary 360°
5	13,450	10,500
6	11,950	8610
8	9730	6540
10	8100	4570
12	5890	3350
14	4830	2720
16	3880	2210
18	3190	1840
20	2680	1500
22	2280	1220
24	1970	1150
26	1700	980
28	1470	830
30	1280	710
31	1200	660

80089499

1. Capacities are in pounds and do not exceed 75% of tipping loads as determined by test in accordance with SAE J765.
2. Capacities are applicable to machines equipped with 10.00x15 (16 ply) at 125 psi cold inflation pressure.
3. Capacities are applicable only with machine on a smooth, level and firm surface.
4. Defined Arc - Over front includes 8° on either side of longitudinal centerline of machine.
5. All rubber lifting depends on proper tire inflation, capacity and condition. Capacities must be reduced for lower tire inflation pressures. Damaged tires are hazardous to safe operation of crane.
6. For pick and carry operation, the boom, using the shortest practical boom length, must be centered over front of machine. Maximum speed is 2.5 mph.
7. On rubber lifting with boom extension not permitted.

**PROVISIONAL**

THIS CHART IS ONLY A GUIDE AND SHOULD NOT BE USED TO OPERATE THE CRANE.

The individual crane's load chart, operating instructions and other instructional plates must be read and understood prior to operating the crane

# Transportation and lifting data

## TRANSPORTATION AND LIFTING DATA

- LIFTING OF ENTIRE CRANE OR MAJOR CRANE ASSEMBLIES MUST BE ACCOMPLISHED BY UTILIZING SPECIFIC FITTINGS INDICATED ON ADJACENT CHART. USE OF FITTINGS FOR PURPOSES OTHER THAN THOSE DESIGNATED ON CHART IS PROHIBITED. FITTING CAPACITIES ARE MAXIMUM ALLOWABLE LOADS PER INDIVIDUAL FITTING.
- RIGGING PERSONNEL SHALL BE RESPONSIBLE FOR PROPER SELECTION AND PLACEMENT OF ALL SLINGS AND LOAD HANDLING DEVICES.
- DIMENSIONS AND WEIGHTS SHOWN ARE ESTIMATED FOR LARGEST CONFIGURATION AVAILABLE. WEIGHTS DO NOT INCLUDE BOOM EXTENSION AND OR JIB, UNLESS OTHERWISE INDICATED.
- RIGGING PERSONNEL SHALL VERIFY DIMENSIONS AS REQUIRED FOR CLEARANCE.
- DO NOT USE COUNTERWEIGHT LIFT LOCATIONS OR BOOM SLING POINT FOR LIFTING OR TIE DOWN OF ENTIRE CRANE.
- LIFTING OF THE COUNTERWEIGHT TO BE ACCOMPLISHED WITH A PROPERLY RATED 1"-8 UNC FITTING.

FITTING	NO. / UNIT				BOOM CWT		CAPACITY-TONNES [TONS]				
		LIFT	TOW	TIE DOWN	LIFT	LIFT	TIE DOWN				
							LIFT	TOW	FORE & AFT	SIDE	DOWN
A	4	X	X	X			18.1 [20]	52.6 [58]	52.6 [58]	6.4 [7]	12.7 [14]
B	4				X		7.3 [8]				
C	2					X	1.6 [1.7]				

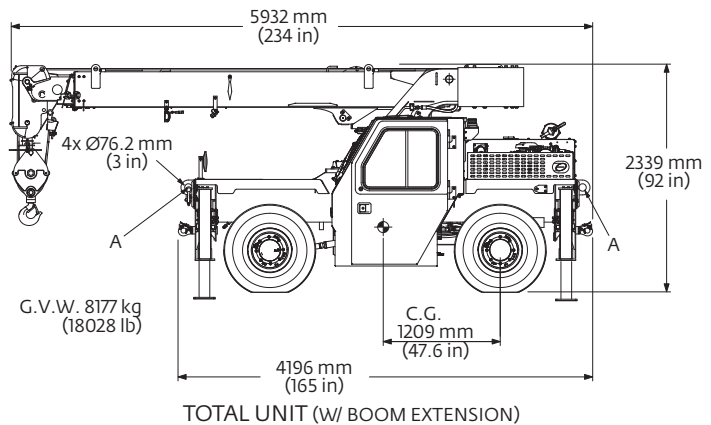
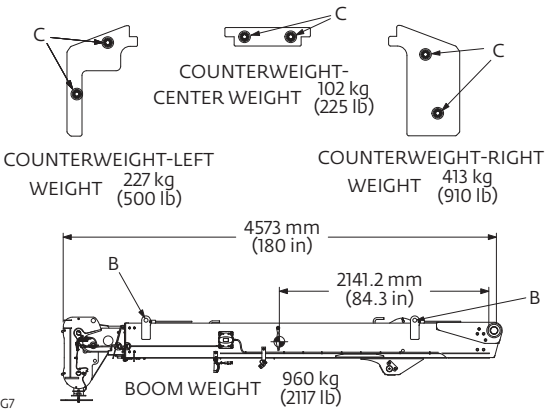

## LOAD DISTRIBUTION FOR CARRYDECK

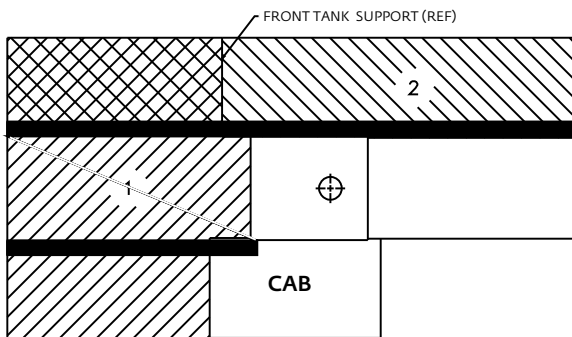

Maximum Allowable Uniformly Distributed Load

**AREA 1**  
14,000 lb

OR

**AREA 2**  
9500 lb

- Maximum travel speed with any or all loads - 2.5 MPH
- Loads to be transported on smooth level firm surfaces only.
- Boom must be retracted and in center forward position, and lowered as much as the load allows.
- Pick and carry loads may be transported on either Deck Area 1 or Deck Area 2; combined loading of Deck Area 1 and Deck Area 2 not permitted.
- Lifting is not permitted when carry deck is loaded except for loading and unloading carry deck.
- The maximum pick and carry loads may be transported on deck area 1 provided the load is centered over the front axle and cribbed directly on the frame rails.

### PROVISIONAL

THIS CHART IS ONLY A GUIDE AND SHOULD NOT BE USED TO OPERATE THE CRANE.

The individual crane's load chart, operating instructions and other instructional plates must be read and understood prior to operating the crane

# Load handling

## WEIGHT REDUCTIONS FOR LOAD HANDLING DEVICES

12 ft FIXED OFFSETTABLE EXTENSION	
*Stowed	N/A
*Erected	740 lb

\*Reduction of main boom capacities

When lifting over swingaway and/or jib combinations, deduct total weight of all load handling devices reeved over main boom nose directly from swingaway or jib capacity.

HOOK BLOCKS AND HEADACHE BALLS	
12.5 USt, one-sheave hook block	187 lb+
6.25 USt downhaul weight	135 lb+

+Refer to rating plate for actual weight

NOTE: All load handling devices and boom attachments are considered part of the load and suitable allowances MUST BE MADE for their combined weights. Weights are for Grove furnished equipment.

TIRE INFLATION - BAR (PSI)		
SIZE (FRONT & REAR)	PLY RATING	LIFTING SERVICE, GENERAL TRAVEL & EXTENDED TRAVEL
		STATIC & 2.5 MPH
SAMSON 10.00x15 LPT	16	125

## LIFTING AREA DIAGRAM

SIDE

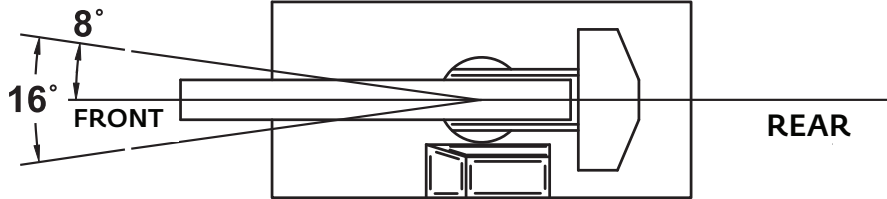

SIDE

## LINE PULLS AND REEVING INFORMATION

HOISTS	CABLE SPECS.	PERMISSIBLE LINE PULLS	NOMINAL CABLE LENGTH
Main	9/16" 6x19 class Bridon EEIPS (XXIPS) Min. breaking strength 37,000 lb	9000 lb*	120 ft
Main	9/16" 8x25 Galv. Min. breaking strength 43,800 lb	9000 lb*	120 ft

The approximate weight of 9/16" wire rope is 0.59 lb/ft.

\*With certain boom and hoist tackle combinations, the allowable line pull may be limited by hoist performance. Refer to hoist performance table for lift planning to ensure adequate hoist performance on drum rope layer required.

### PROVISIONAL

THIS CHART IS ONLY A GUIDE AND SHOULD NOT BE USED TO OPERATE THE CRANE.

The individual crane's load chart, operating instructions and other instructional plates must be read and understood prior to operating the crane

## Superstructure

### Boom

4,3 m – 10,1 m (14.2 ft - 33.2 ft) full-power main boom. Three-section, full-power, proportional boom.

Maximum tip height: 11,3 m (37 ft)



### \*Optional swingaway extension\*

3,6 m (12 ft) offsettable swingaway extension. Offsets 0°, 15° and 30° via pivoting boom nose. Stows alongside base boom section.

Maximum tip height: 14,6 m (48 ft)



### Boom nose

Nylatron sheaves mounted on heavy-duty needle roller bearings with removable pin type rope guards. Quick reeve type boom nose with three positions (0°, +40° and +80°) pivoting to minimize head height requirements. Lowers head height by 0,4 m (1.3 ft).



### Boom elevation

Single double acting hydraulic cylinders with integral holding valves provides elevation from 0° to +70°.



### Anti-two block device

Standard anti-two block device, which, when activated, provides an audible warning to the operator and “locks-out” all functions whose movement can cause two-blocking.



### Rated Capacity Limiter (RCL)

Color, graphical display of boom angle, boom length, boom radius, rated load and calculated load. Allows for operator inputs to set the crane configuration. RCL system is hardwired and calculates load via pressure transducers in the lift cylinder. Display includes a color-coded light bar and audible alarm with function cut-out if load exceeds the load chart parameters.



### Swing

Ball bearing swing circle with 360° continuous rotation. Worm gear and pinion driven by hydraulic motor.  
Maximum speed: 2.05 rpm



### Hydraulic system

One pressure compensated variable displacement axial piston pump with load sensing.

Maximum output of: 151 lpm (40 gpm).

Maximum operating pressure: 172 bar (2500 psi).

Four-section valve bank, chassis mounted, operated via dash mounted, hydraulic pilot controls. 98.04 L (25.9 gal) hydraulic reservoir with sight level gauge.

3 micron return line filter with full flow by-pass protection and service indicator.



### Hoist specifications

Geroler motor driven with automatic spring-applied / hydraulically released wet brake. Drum rotation indicator in the hoist joystick control and hoist direction indicator light on dashboard.

Maximum hoist pull (first layer): 4885 kg (10,769 lb)

Maximum permissible single line pull: 4082 kg (9000 lb)  
(3.5:1 design factor)

Maximum single line speed: 34 m/mm (112 fpm)

Rope construction: 6X19 XXIPS IWRC

Rope diameter: 14 mm (9/16 in)

Rope length: Main hoist: 36.6 m (120 ft)

Maximum usable rope: Main hoist: 38 m (125 ft)

## Carrier



### Chassis

High-strength alloy frame constructed with integral outrigger housings; front and rear lifting, tie-down, and towing lugs. 2,34 m<sup>2</sup> (25.2 ft<sup>2</sup>) carrydeck size with 6350 kg (14,000 lb) deck only carrying capacity. Deck coated with anti-skid treatment.



### Outriggers

Hydraulic telescoping beam with oblique type jack provides extended and down retracted and down lifting capacities. Integral holding valves on both beam and jack.

Outrigger pad size:

203,2 mm x 200 mm (8 in x 7.87 in) rectangular steel fabrication

Maximum outrigger pad load: 6795 kg (14,980 lb)



### Outrigger controls

Independent outrigger controls. 360° bubble level located inside cab.



### Engine (EPA Tier 4F)

Cummins QSB 2.8 L, four-cylinder / turbo charged water cooled diesel rated at 55.1 kW (74 hp) at 2,500 rpm, includes Cummins catalyst, hour meter, cold start aid (grid heater), 120V engine block heater, and air filter service indicator. Engine shut down feature. Meets EPA emissions. Requires maximum 15 ppm "Ultra Low Sulfur Diesel." Required for USA and Canada.



### Engine (EPA Tier 3)

\*Please consult factory for availability.

Cummins QSF2.8 EPA, CARB (Tier III) off-highway certified; 4 cylinder turbo charged water cooled diesel; 72 hp @ 2400 RPM. Engine hour meter located in dash display.

Maximum torque: 270 N-m (199 lb-ft) at 1,440-1,800 rpm

Note: Required for sale outside the USA, Canada and European Union; good for up to 5000 ppm sulfur diesel fuel.

*\*Denotes optional equipment*

# Specifications



## Engine (Dual Fuel)

GM3.0L EFI gasoline /LP gas engine, 07 EPA and CARB certified, 78 hp at 2500 RPM (gasoline) and 63 hp at 2500 RPM (LPG), with engine shutdown feature. (LP tank not included.)



## Fuel tank capacity

67 L (17.7 gal)



## Transmission

Powershift with four speeds forward and three speeds reverse. Stalk mounted direction shifter with rotary gear selection.



## Operators control station

Frame mounted, open air style control station with cab shell includes all crane functions, driving controls, and overhead safety glass. Other standard equipment includes a deluxe seat with seat belt, hour meter sight level bubble and 1,13 kg (2.5 lb) fire extinguisher.

The dash panel includes a multi-cluster gauge showing fuel, water temperature, battery voltage and engine fault codes. An engine monitoring indicator lamp shows engine warning, stop engine, wait to start, transmission high temperature, low brake system pressure, and hydraulic oil temperature. The RCL display is mounted to the top of the front dash.



## \*Operators control station enclosed

Includes the standard cab shell with the addition of front, rear and right side glass, a split (2 piece) hinged door with sliding glass, front windshield wiper and washer, hot water heater and defroster with fan and cab dome light are included



## Electrical system

One 12 V maintenance-free battery, 730 CCA each at 0°.  
105 amp alternator Dual fuel  
120 amp alternator T3 and T4



## Drive

Front-wheel drive as standard



## Steering

Standard three steering modes. Front two-wheel, four-wheel coordinated, and four-wheel crab steer with electronic self-alignment, three-position rocker selector on dash panel.

Outside turning radius:

Two-wheel steer: 5050 mm 198.8 in

Four-wheel steer: 3180 mm 125.2 in



## Axles

Front: Drive/steer

Rear: Non-drive/steer

Front and rear axle are rigid mounted to frame.



## Brakes

Hydraulic actuated internal wet-disc service brakes acting on front wheels. Dash mounted toggle switch with light for activating or release of the dry disc parking brake mounted on the axle input.



## Tires

Standard: 10.00 x 15, 16 ply, bias type tires



## Light

Full lighting including turn indicators, head, tail brake and hazard warning light recessed mounted.



## Maximum speed

30.9 km/h (19.2 mph)



## Gradeability (theoretical)

Gas 84.8% with 9072 kg (14,000 lb) load

LP 69.2% with 9072 kg (14,000 lb) load

Diesel 90.3% with 9072 kg (14,000 lb) load

## Gross vehicle weight (GVW)

Dual Fuel with open cab:

7677 kg (16,924 lb)

Dual Fuel with enclosed cab:

7805 kg (17,208 lb)

## Miscellaneous standard equipment

- Back-up motion alarm
- Outrigger motion alarm
- Hoist drum rotation indicator

## \*Optional equipment

- Auxiliary lighting: includes amber strobe light and boom mounted work lights
- Convenience package: includes front and rear pintle hitch and headlight/taillight grille covers
- Enclosed cab package: includes heater and defroster, cab dome light, all window glass, and two-piece split door
- Offsettable swing away boom extension with hook and downhaul weight
- Air conditioner
- 3401,9 kg (7500 lb) capacity hydraulic below-deck mounted tow winch
- Searcher hook

*\*Denotes optional equipment*

# Specifications



Axles



Drive



Hoist



Rated Capacity Limiter (RCL)



Boom



Electrical system



Hook block



Rotation



Boom elevation



Engine



Hydraulic system



Speed



Boom extension



Extension



Insert



Steering



Boom length



Frame



Lights



Suspension



Boom nose



Fuel tank capacity



Oil



Swing



Brakes



Gear



Outrigger controls



Tires



Cab



Grade



Outriggers



Transmission



Counterweight



Heavy-duty jib



Radius

## Manitowoc Cranes

### Regional headquarters

#### Americas

**Manitowoc, Wisconsin, USA**

Tel: +1 920 684 4410

Fax: +1 920 652 9778

**Shady Grove, Pennsylvania, USA**

Tel: +1 717 597 8121

Fax: +1 717 597 4062

#### Europe, Middle East, Africa

**Dardilly, France - TOWERS**

Tel: +33 (0)4 72 18 20 20

Fax: +33 (0)4 72 18 20 00

**Wilhelmshaven, Germany - MOBILE**

Tel: +49 (0) 4421 294 0

Fax: +49 (0) 4421 294 4301

#### China

**Shanghai, China**

Tel: +86 21 6457 0066

Fax: +86 21 6457 4955

#### Middle East and Greater Asia-Pacific

**Singapore**

Tel: +65 6264 1188

Fax: +65 6862 4040

**Dubai, UAE**

Tel: +971 4 8862677

Fax: +971 4 8862678/79



This document is non-contractual. Constant improvement and engineering progress make it necessary that we reserve the right to make specification, equipment, and price changes without notice. Illustrations shown may include optional equipment and accessories and may not include all standard equipment.